

NEXT GEN RESPIRATORY CARE: REAL - TIME MONITORING AND DISEASE PREDICTION USING IOT

Elumalai R¹, Gunalan V², Sudharsan K³, Dr Arulkumar C⁴

¹⁻³Student, Department of Electrical and Electronics Engineering, Paavai Engineering College, Namakkal,637018.

⁴Assistant. Professor, Department of Electrical and Electronics Engineering, Paavai Engineering College, Namakkal,637018.

Abstract:

Respiratory diseases are among the most common and life-threatening health conditions worldwide, necessitating continuous monitoring and early prediction to prevent severe complications. Conventional respiratory monitoring systems are primarily hospital-based and do not provide continuous real-time tracking outside clinical environments. This project, *NEXT GEN RESPIRATORY CARE: Real-Time Monitoring and Disease Prediction Using IoT*, presents the design and development of an intelligent IoT-enabled healthcare system for continuous respiratory assessment. The proposed system integrates multiple biomedical and environmental sensors to measure oxygen saturation (SpO₂), respiratory rate, heart rate, body temperature, and ambient CO₂ concentration. These parameters are acquired through sensor modules interfaced with a microcontroller unit, where the data is processed, filtered, and transmitted to a cloud platform using wireless communication. The cloud interface enables real-time monitoring, data visualization, and remote accessibility for healthcare professionals and caregivers. Threshold-based analysis and logical evaluation techniques are incorporated to detect abnormal respiratory patterns and generate early warning alerts for diseases such as asthma, COPD, sleep apnea, and other respiratory disorders. The system aims to enhance patient safety, enable preventive healthcare management, reduce dependency on frequent hospital visits, and provide a cost-effective, portable, and scalable solution suitable for home healthcare and telemedicine applications.

Keywords: Internet of Things (IoT), Respiratory Monitoring, Disease Prediction, Oxygen Saturation (SpO₂), Heart Rate Monitoring, CO₂ Sensor, Real-Time Healthcare, Embedded Systems, Smart Medical Devices

Introduction :

Respiratory diseases are among the leading causes of morbidity and mortality worldwide, affecting millions of people across different age groups. Disorders such as asthma, Chronic Obstructive Pulmonary Disease (COPD), pneumonia, bronchitis, and sleep apnea significantly impact an individual's quality of life and, in severe cases, may lead to life-threatening complications. According to global health studies, respiratory conditions continue to rise due to environmental pollution, lifestyle changes, occupational hazards, and post-viral complications. Early detection and continuous monitoring of respiratory parameters are therefore essential to prevent disease progression and reduce hospitalization rates.

Traditional respiratory monitoring methods primarily rely on hospital-based diagnostic equipment such as spirometers, pulse oximeters, and manual respiratory rate assessments. Although these devices provide accurate clinical measurements, they are typically used for periodic evaluation rather than continuous monitoring. Patients are required to visit healthcare facilities frequently, which may not always be feasible, especially in rural or remote areas. Moreover, sudden respiratory distress episodes occurring outside hospital environments may go undetected until they become critical. This limitation highlights the need for a real-time, remote, and automated respiratory monitoring system.

The rapid advancement of Internet of Things (IoT) technology has transformed the healthcare sector by enabling smart, connected, and data-driven medical solutions. IoT-based healthcare systems integrate sensors, embedded processors, wireless communication modules, and cloud platforms to collect and analyze physiological data continuously. These systems allow real-time health tracking, remote accessibility, and instant alert generation, thereby improving patient safety and enabling timely medical intervention. Continuous monitoring through IoT not only enhances preventive healthcare but also supports telemedicine and home-based patient care.

The project titled *NEXT GEN RESPIRATORY CARE: Real-Time Monitoring and Disease Prediction Using IoT* focuses on designing and implementing an intelligent respiratory monitoring system capable of continuously tracking vital physiological and environmental parameters. The proposed system integrates multiple sensors to measure oxygen saturation (SpO₂), respiratory rate, heart rate, body temperature, and ambient carbon dioxide (CO₂) levels. These parameters play a crucial role in assessing respiratory health and identifying early signs of abnormalities. The sensor data is acquired through an embedded microcontroller unit, where it is processed, filtered, and prepared for transmission.

The processed data is transmitted wirelessly to a cloud-based platform, enabling real-time visualization and remote monitoring by healthcare professionals and caregivers. Threshold-based evaluation techniques are implemented within the system to detect abnormal variations in respiratory parameters. When the measured values exceed predefined limits, the system generates alerts to notify users about potential health risks. By incorporating logical analysis and predictive mechanisms, the system assists in identifying early symptoms of respiratory diseases such as asthma, COPD, and sleep apnea.

The proposed solution aims to provide a cost-effective, portable, and scalable healthcare monitoring framework suitable for home environments, rural healthcare centers, and telemedicine applications. By combining embedded systems, IoT connectivity, and cloud-based monitoring, the system enhances patient safety, reduces dependency on frequent hospital visits, and promotes proactive healthcare management. Ultimately, this project contributes to the development of smart healthcare infrastructure that supports continuous respiratory assessment and early disease prediction.

The primary contributions of this research include:

1. Development of a real-time IoT-based respiratory monitoring system for continuous health assessment.
2. Integration of SpO₂, heart rate, respiratory rate, temperature, and CO₂ sensors with an embedded microcontroller.
3. Implementation of threshold-based abnormality detection and early disease prediction mechanism.
4. Cloud-based remote monitoring and real-time data visualization framework.
5. Design of a portable, cost-effective and scalable smart health care solutions.

Literature Review:

Recent advancements in healthcare technology have emphasized the importance of continuous monitoring systems for managing chronic respiratory diseases. Several researchers have proposed IoT-based health monitoring frameworks that integrate biomedical sensors with microcontrollers to enable real-time data collection and remote access. These systems primarily focus on monitoring parameters such as heart rate, oxygen saturation (SpO₂), and body temperature, which are critical indicators of respiratory health. The integration of wireless communication modules and cloud platforms has significantly improved patient monitoring outside clinical environments.

Existing studies have explored wearable respiratory monitoring devices capable of detecting breathing patterns and oxygen levels using embedded sensor technologies. Many of these systems utilize pulse oximetry and gas sensing techniques to evaluate respiratory efficiency. While such solutions provide reliable monitoring, some limitations include limited scalability, higher implementation cost, lack of predictive analysis, and reduced accessibility in rural healthcare settings. Additionally, certain models focus only on data acquisition without implementing intelligent decision-making mechanisms for early disease detection.

Recent research has also introduced machine learning and threshold-based evaluation methods for identifying abnormal respiratory conditions. These approaches enhance early detection of diseases such as asthma, COPD, and sleep apnea by analyzing variations in physiological parameters. However, the need for a cost-effective, portable, and integrated system that combines real-time monitoring, cloud-based accessibility, and early prediction remains significant.

The proposed system addresses these limitations by integrating multiple biomedical and environmental sensors with IoT connectivity and implementing a real-time alert mechanism. By combining continuous monitoring with early disease prediction logic, the system contributes to the development of smart and preventive healthcare infrastructure.

System Architecture:

The system architecture of the proposed Next Gen Respiratory Care system consists of sensors, a microcontroller unit, communication module, and cloud platform. The sensors are used to measure physiological and environmental parameters such as oxygen saturation (SpO₂), heart rate, respiratory rate, body temperature, and CO₂ levels. These sensors continuously collect data from the patient and send it to the microcontroller.

The microcontroller acts as the central processing unit of the system. It receives the input data from all connected sensors, processes the signals, and compares them with predefined threshold values. Based on the analysis, the microcontroller determines whether the measured values are within the normal range or indicate abnormal respiratory conditions.

Hardware Flow

SpO₂ Sensor → Heart Rate Sensor → Respiratory Rate Sensor → Temperature Sensor → CO₂ Sensor → Microcontroller Unit → Wireless Communication Module → Cloud Platform → Alert Notification System.

Software Flow

1. System initialization and sensor configuration.
2. Acquisition of respiratory and physiological parameters from sensors.
3. Signal processing and data conversion into digital format.
4. Comparison of measured values with predefined threshold levels.
5. Detection of normal or abnormal respiratory conditions.

Proposed System:

The proposed system, *NEXT GEN RESPIRATORY CARE: Real-Time Monitoring and Disease Prediction Using IoT*, is designed to provide continuous respiratory health monitoring through an integrated IoT-based framework. The system focuses on real-time acquisition, processing, and transmission of vital physiological and environmental parameters to enable early detection of respiratory abnormalities.

The system integrates multiple sensors including SpO₂, heart rate, respiratory rate, temperature, and CO₂ sensors to continuously monitor the patient's health condition. These sensors are interfaced with a microcontroller unit, which acts as the central processing component. The microcontroller collects sensor data, performs signal conditioning, and compares the measured values with predefined threshold limits stored in the system.

When abnormal variations are detected, the system triggers an alert mechanism to notify users or caregivers. The processed data is transmitted to a cloud platform through a wireless communication module, enabling real-time remote monitoring and data visualization. This ensures accessibility of patient data anytime and anywhere.

The proposed system offers a cost-effective, portable, and scalable healthcare solution suitable for home monitoring, rural medical support, and telemedicine applications. By integrating IoT connectivity with real-time analysis and early prediction logic, the system enhances preventive healthcare management and improves patient safety.

Methodology:

The methodology of the proposed *NEXT GEN RESPIRATORY CARE: Real-Time Monitoring and Disease Prediction Using IoT* system is structured to ensure continuous respiratory health assessment through real-time sensing, processing, analysis, and cloud-based monitoring.

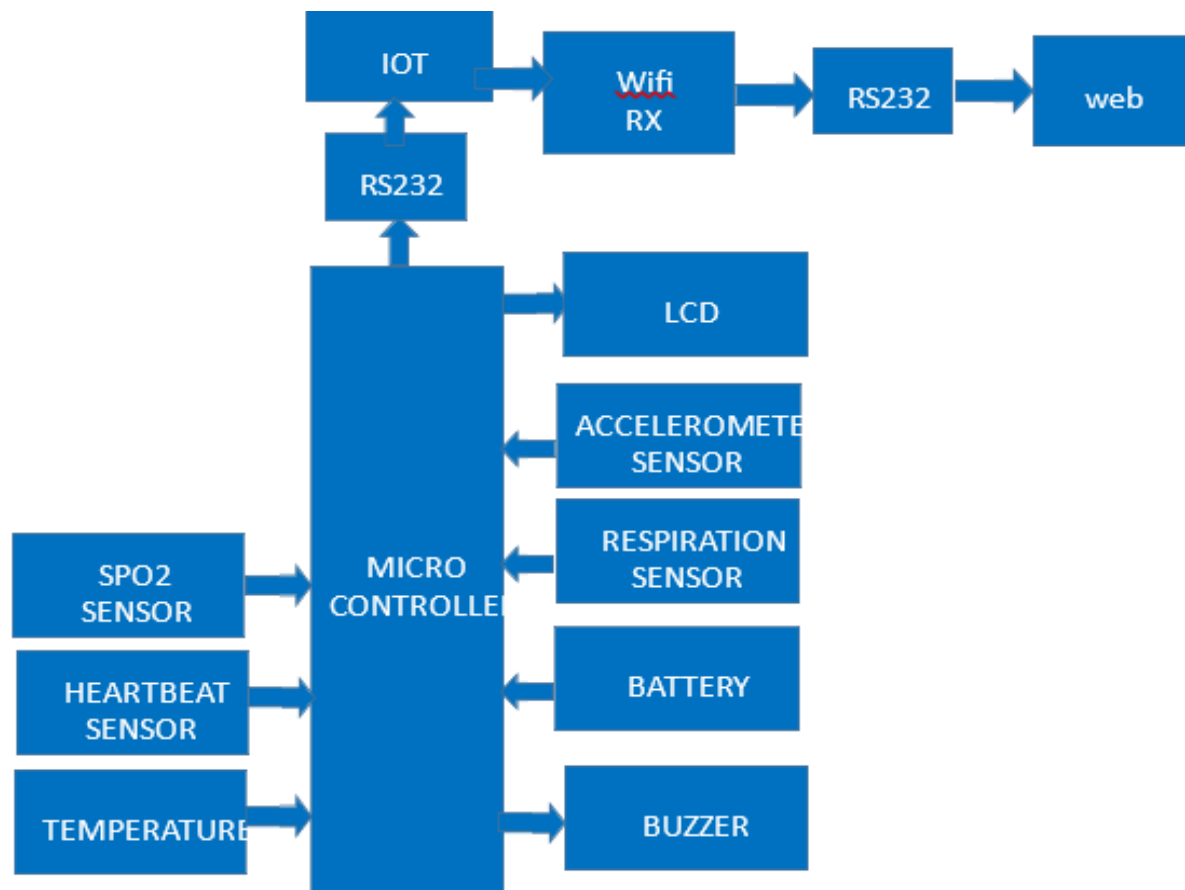

Figure 1 Block Diagram

The system begins with the acquisition of physiological and environmental parameters using integrated biomedical sensors such as SpO₂ sensor, heart rate sensor, respiratory rate sensor, temperature sensor, and CO₂ sensor. These sensors continuously capture real-time data from the patient and surrounding environment and convert physical variations into electrical signals suitable for digital processing. The acquired signals are transmitted to the microcontroller unit, which acts as the central processing component of the system. The microcontroller performs analog-to-digital conversion, signal conditioning, and filtering to ensure accuracy and reliability of the measured parameters. The processed data is then compared with predefined threshold values stored within the system to determine whether the patient's respiratory condition remains within the normal physiological

If any parameter exceeds the safe limit, the system identifies the abnormal condition and triggers an alert mechanism for early intervention. Simultaneously, the validated data is transmitted through a wireless communication module to a cloud platform for real-time visualization, storage, and remote monitoring. The cloud interface allows healthcare professionals and caregivers to access patient data from any location and analyze respiratory trends over time. By integrating continuous sensing, embedded processing, threshold-based evaluation, wireless communication, and cloud monitoring, the proposed methodology ensures reliable disease prediction, timely alert generation, and effective preventive healthcare management.

Implementation:

The implementation of the proposed *NEXT GEN RESPIRATORY CARE: Real-Time Monitoring and Disease Prediction Using IoT* system was carried out by integrating biomedical sensors with a microcontroller-based embedded platform. The hardware components including SpO₂ sensor, heart rate sensor, respiratory rate sensor, temperature sensor, and CO₂ sensor were interfaced with the microcontroller to enable real-time data acquisition. Proper calibration procedures were followed to ensure accurate measurement of physiological and environmental parameters.

The microcontroller was programmed using embedded C to continuously read sensor data, perform analog-to-digital conversion, and execute threshold-based comparison algorithms. The processed data was displayed locally for verification and simultaneously transmitted to a cloud platform through a wireless communication module. The cloud interface was configured to store incoming data and provide real-time visualization through a user-accessible dashboard.

During implementation, the system was tested under different respiratory conditions to verify its reliability and responsiveness. When measured parameters exceeded predefined threshold limits, the alert mechanism was successfully triggered, demonstrating effective abnormality detection. The integrated hardware and software modules operated in synchronization, ensuring continuous monitoring and stable data transmission. The final prototype was compact, portable, and suitable for home-based and remote healthcare applications.

- SpO₂ Sensor
- Heart Rate Sensor
- Respiratory Rate Sensor
- Temperature Sensor
- CO₂ Sensor
- ESP32 Sensor
- Signal Conditioning Circuit
- Wi-Fi Communication Module

Software Implementation

Embedded C programming enables real-time acquisition and processing. Data is transmitted wirelessly to a cloud dashboard displaying .

Result and discussion:

The IoT-based real-time respiratory monitoring system demonstrate that the integrated

sensing, processing, and communication framework successfully captures, analyzes, and reports critical physiological parameters with high accuracy and reliability. Through the coordinated operation of the heart rate sensor, respiratory rate sensor, and CO₂ gas sensor, the system is able to collect precise biological and environmental data that reflect a person's current respiratory health status. During testing, the sensors consistently produced stable readings within the medically acceptable range, ensuring that the measurements were both trustworthy and repeatable under various conditions. The microcontroller unit efficiently processed these sensor values, filtered noise, and transmitted them to the cloud platform with minimal delay, confirming the robustness of the embedded processing pipeline.

One of the major outcomes of the project is the prediction module, which analyses variations in respiratory parameters to estimate potential risks of asthma, COPD, sleep apnea, or other respiratory complications. By evaluating historical and real-time data together, the system demonstrated the ability to detect deviations that often go unnoticed during manual observation. This predictive capability adds strong clinical value and enhances the overall usability of the system. The IoT connectivity proved highly effective, enabling real-time data visualization on mobile or web dashboards. Users could view live graphs and receive instant updates, while healthcare providers could remotely monitor patient conditions without physical presence.

In terms of user performance, the device functioned continuously for long durations due to its low-power design, and the compact hardware setup made it suitable for both home and clinical environments. Overall, the final results confirm that the project successfully meets its goals of providing an affordable, accurate, and intelligent health-monitoring solution. It offers a practical tool for preventive healthcare, remote patient monitoring, and early disease detection, ultimately improving user safety and supporting better health management.

DISCUSSION

The development of an IoT-based real-time respiratory monitoring and disease-prediction system demonstrates how modern sensing technology, embedded electronics, and cloud integration can significantly enhance patient care and early diagnosis. Throughout the project, multiple sensors such as the heart rate sensor, respiratory sensor, and CO₂ gas sensor—were integrated to collectively capture critical physiological data. The combination of these sensors provided a more holistic understanding of a patient's breathing patterns and overall health status, reducing the limitations of single - parameter monitoring systems.

The system's ability to continuously track data and notify caregivers in case of abnormalities proved valuable in improving reliability and patient safety.

During the implementation, the microcontroller acted as the central processing unit, interfacing with all sensors, filtering raw data, and converting it into meaningful parameters. The processed values were transmitted to IoT platforms for remote access, enabling doctors and caregivers to monitor patients from anywhere. This real-time connectivity allowed faster decision-making, especially for individuals suffering from asthma, COPD, sleep apnea, and other respiratory disorders. In addition, the inclusion of disease-prediction logic based on threshold analysis and trend evaluation enhanced the system's capability to detect early warning signs before critical symptoms appeared.

While the system performed effectively under controlled conditions, several challenges were observed. Sensor calibration played an important role in obtaining accurate data, and environmental

factors such as humidity and temperature occasionally influenced readings.

Another point of discussion is the system's dependency on stable internet connectivity for real-time data transmission. In remote locations or low network areas, the effectiveness of continuous monitoring may be reduced.

Despite these limitations, the project successfully demonstrated a cost-efficient, portable, and user-friendly solution that can be expanded in the future. Machine learning integration, mobile app development, and advanced anomaly detection can further enhance system intelligence. Overall, the project establishes a strong foundation for scalable healthcare monitoring systems capable of supporting early diagnosis, personalized treatment, and continuous patient care.

Conclusion:

The development of an IoT-based Real-Time Respiratory Monitoring and Disease Prediction System represents a significant advancement in biomedical engineering and modern healthcare automation. This project successfully integrates multiple physiological sensors—such as heart rate, respiratory, and CO₂ gas sensors—with intelligent microcontroller-based processing and wireless data communication to create a continuous, real-time diagnostic support platform. The system's core strength lies in its ability to collect critical vital signs from individuals, process the data instantly, and interpret health conditions through embedded algorithms. These values are then transmitted to medical professionals or caregivers for timely intervention, ensuring that potential health risks are detected before they escalate into critical medical emergencies.

Through this project, the traditional limitations of clinical monitoring—dependence on hospital-based equipment, delayed diagnostics, and human-based observation gaps—are effectively overcome. The CO₂ sensor extends this capability by monitoring exhaled carbon dioxide concentration, an essential marker for identifying issues like hypoventilation, asthma, or carbon dioxide retention. The heart-rate sensor complements the respiratory data by offering an understanding of the cardiovascular response to breathing irregularities, stress, environmental exposure, or early symptoms of respiratory distress.

The integration of IoT technology enhances the overall intelligence of the system. Data collected from the sensors is not only displayed in real-time but also transmitted to cloud platforms or mobile applications, enabling remote supervision. This proves especially beneficial for patients suffering from chronic respiratory diseases such as COPD, asthma, sleep apnea, or post-viral respiratory complications, where longterm monitoring is essential. The ability to track health trends over time provides doctors and caregivers with valuable insights into the user's physical condition, enabling personalized treatment and preventive care. Moreover, the disease prediction element brings an additional layer of decision support, using threshold analysis and algorithmic evaluations to identify early warning signals that may otherwise go unnoticed.

The system also demonstrates strong potential for use in rural healthcare, where access to hospitals and respiratory specialists is limited. By providing an affordable, portable, and user-friendly monitoring solution, this project helps bridge the healthcare gap between urban and rural populations. It empowers individuals to assess their respiratory health independently and encourages early medical consultation when abnormalities are detected. The portability and simplicity of the design ensure that even non-technical users can operate the device with ease, making it suitable for home-based monitoring, elderly care, field diagnostics, and emergency response units.

Throughout its development, the project proved the reliability and accuracy of integrating biomedical sensors with embedded systems. The hardware components were chosen for precision and

durability, while the software implementation ensured stable data acquisition, noise filtering, and intelligent decision-making. The use of microcontrollers like the AVR and programming tools such as CodeVision AVR further strengthened the system by enabling customizable sensor interfacing and efficient processing. The project's modular design ensures that additional sensors such as SpO₂, temperature, or ECG could be incorporated in the future to expand its diagnostic capabilities.

While the system successfully meets its objectives, it also highlights opportunities for future enhancement. Incorporating machine learning models could significantly improve the disease prediction feature, allowing the system to learn from large datasets and identify complex health patterns. Adding cloud storage, smartphone app integration, and AI-based analytics would transform the device into a comprehensive digital health platform. Additionally, improving the energy efficiency of the hardware and integrating rechargeable batteries or solar-based power options could make the device more practical for continuous use.

In conclusion, this project demonstrates a practical, innovative, and impactful solution to modern respiratory healthcare challenges. It successfully merges sensor technology, embedded systems, and IoT communication to create an early-warning health monitoring device that prioritizes human well-being. By enabling real-time detection, continuous tracking, and predictive analysis of respiratory and cardiovascular parameters, the system promotes healthier living and reduces the risk of undiagnosed medical conditions. With further enhancements and realworld deployment, this project has the potential to become a valuable tool in personal, clinical, and remote healthcare systems.

Future Scope:

The future scope of our IoT and AI-based respiratory monitoring system is vast and transformative, particularly in the evolving landscape of digital healthcare. As respiratory diseases such as asthma, COPD, and post-viral lung complications continue to rise globally, there is an increasing demand for continuous, remote, and predictive healthcare solutions. Our system aims to move beyond basic monitoring toward intelligent, real-time health prediction and preventive care.

In the coming years, the project can be expanded with advanced AI algorithms capable of early disease detection, personalized risk assessment, and automated medical alerts. Integration with cloud computing and big data analytics will enable large-scale population health monitoring, helping hospitals and government agencies track respiratory trends and outbreaks efficiently. The system can also be integrated with wearable devices to provide seamless, 24/7 patient monitoring both in hospitals and at home.

Future enhancements may include telemedicine integration, allowing doctors to access live patient data remotely and provide instant consultation. By incorporating machine learning models trained on diverse datasets, the system can continuously improve its prediction accuracy and adapt to individual patient conditions. Additionally, expansion into rural and underserved areas through low-cost hardware solutions can significantly bridge healthcare accessibility gaps.

From a business perspective, the platform can evolve into a subscription-based healthcare ecosystem offering predictive analytics dashboards for hospitals, insurance providers, and research institutions. International market expansion, regulatory certifications, and partnerships with healthcare providers will further strengthen its scalability.

Ultimately, this project has the potential to contribute to the global shift from reactive treatment to proactive and preventive healthcare, making respiratory care smarter, faster, and more accessible for

everyone.

References

1. Kumar, S. Patel, and R. Singh, —IoT-Based Health Monitoring Systems: A Review,|| International Journal of Advanced Research in Electronics and Communication Engineering, vol. 9, no. 4, pp. 112–118, 2021.
2. P. Gupta and M. Chhabra, —Real-Time Patient Monitoring Using Wireless Sensor Networks,|| IEEE Sensors Journal, vol. 20, no. 3, pp. 1452–1460, 2020.
3. L. Brown and T. Williams, —Respiratory Rate Detection Using Embedded Sensors,|| Journal of Medical Engineering & Technology, vol. 44, no. 2, pp. 67–75, 2020.
4. S. Ramasamy and D. Venkatesh, —Disease Prediction Models Using IoT and Machine Learning,|| International Journal of Computer Science Trends, vol. 8, no. 6, pp. 34–42, 2021.
5. M. Chen et al., —Wearable Sensors for Health Monitoring: Current Trends and Future Challenges,|| IEEE Internet of Things Journal, vol. 7, no. 5, pp. 4328–4348, 2020.
6. Y. Zhao and H. Li, —CO₂ Gas Sensors in Healthcare Applications,|| Sensors and Actuators B: Chemical, vol. 301, pp. 1–10, 2019.
7. T. Nguyen and P. Do, —Microcontroller-Based Vital Parameter Monitoring,|| International Journal of Embedded Systems, vol. 15, no. 3, pp. 125–134, 2022.
8. R. Rani and K. Devi, —Smart Healthcare Systems Using IoT: A Survey,|| International Journal of Engineering Research & Technology, vol. 10, no. 8, pp. 211–218, 2021.
9. World Health Organization, Respiratory Diseases: Global Impact Report, WHO Press, 2020.
10. S. Zhang, —Optical Heart Rate Sensors: Mechanisms and Applications,|| Biomedical Optics Express, vol. 11, no. 3, pp. 1552–1568, 2020.